

WAFER STYLE KNIFE GATE VALVE

The EX model knife gate is an uni-directional wafer valve designed for general industrial service applications. The design of the body and seat assures non-clogging shut off on suspended solids in industries such as:

- Pulp and Paper
- Wastewater treatment plants
- Food and Beverage
- Mining
- Power plants
- Chemical plants
- Bulk handling
- Etc.

Sizes: DN 50 to DN 1200 (larger diameters on request)

Working pressure:

DN 50 to DN 250	10 bar
DN 300 to DN 400	6 bar
DN 450	5 bar
DN 500 to DN 600	4 bar
DN 700 to DN 1200	2 bar

Standard flange connection:

DIN PN 10 and ANSI B16.5 (class 150)
Other flange connections available on request

DIN PN 6	DIN PN 16	DIN PN 25
BS "D" and "E"	ANSI 125	

Directives: For EU Directives and other Certificates please see the document:
Directives & Certificates Compliance - Knife Gate Valves –
Catalogues and Datasheets



All valves are tested prior to shipping in accordance with the standard developed by the Quality Control Department at ORBINOX.

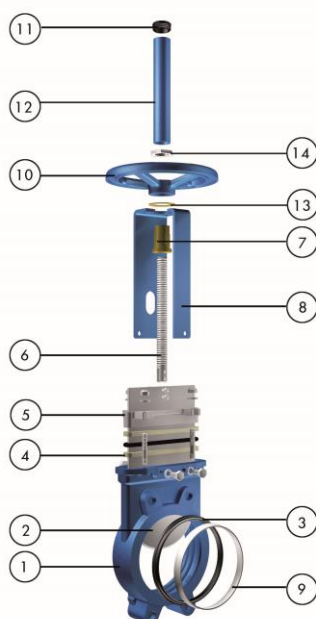

STANDARD PARTS LIST

Part:	Cast Iron:	Stainless Steel:
1- Body	GJL250(GG25)	CF8M
2- Gate	AISI 304	AISI 316
3- Seat	Metal/Metal or EPDM	
4- Packing	PTFE Impreg. Synth. Fibre (With a EPDM O-Ring)	
5- Gland Follower	Alum. (DN 50 to DN 300) or Ductile Iron (DN 350 a DN 1200)	CF8M
6- Stem	Stainless Steel	
7- Stem nut	Brass	
8- Yoke	Epoxy-coated Carbon Steel	
9- "A" ring	AISI 304	AISI 316
10- Handwheel	GJS400 (GGG40)	
11.- Cap	Plastic	
12- Stem Protector	Epoxy-coated Carbon Steel	
13- Friction Washer	Brass	
14- Nut	Zinc Plated Carbon Steel	

DESIGN FEATURES

BODY:

Wafer style cast monoblock with raised faces and reinforcing ribs in large diameters for extra body strength. Internal cast-in gate wedges and guides allow for a tighter shut-off between gate and seat. Full port design for greater flow capacity and minimal pressure drop. The internal body design avoids any accumulation of solids that would prevent the valve from closing.

GATE:

Stainless steel gate. Gate is polished on both sides to avoid jamming and seat damage. Bottom of the gate edge is machined to a bevel to cut through solids for a tighter seal in the closed position. The thickness and/or material of the gate can be changed on request for higher pressure requirements.

SEAT: (resilient)

Unique design that mechanically locks the seal in the internal of the valve body with a stainless steel retainer ring. Standard EPDM also available in different materials such as Viton, PTFE, etc.

PACKING:

Long-life packing with several layers of braided fibre plus an EPDM o-ring, with an easy access packing gland ensuring a tight seal. Long-life braided packing is available in a wide range of materials.

STEM:

The standard stainlesssteel stem offers a long corrosion resistant life. For rising stem handwheel actuators only, a stem protector is provided for additional protection against dust while the valve is in the open position.

ACTUATORS:

All actuators supplied by ORBINOX are interchangeable, and supplied with a standard mounting kit for installation purposes on site.

YOKE or ACTUATOR SUPPORT:

Made of EPOXY coated steel (stainless steel available on request). Compact design makes it extremely robust even under the most severe conditions.

EPOXY COATING:

The epoxy coating on all ORBINOX cast iron and carbon steel valve bodies and components is applied by means of an electrostatic process, making the valves corrosion-resistant with a high quality finished surface. The ORBINOX standard colour is RAL-5015 blue.

GATE SAFETY PROTECTION:

ORBINOX automated valves are provided with gate guards in accordance with EU Safety Standards. The design feature prevents any objects from being caught accidentally while the gate is moving.

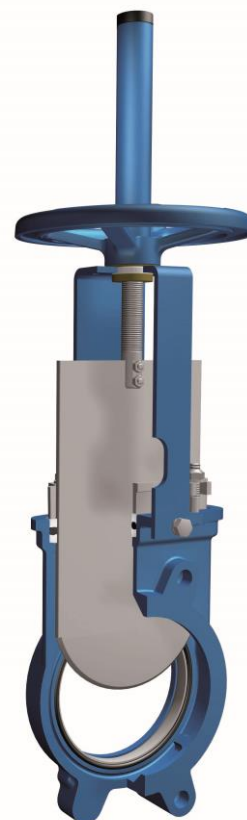

OTHER OPTIONS

Bonnet (Fig.1):

Assures tight sealing to atmosphere.
Reduces packing maintenance.

V-port:

60 degree and pentagonal port design. Selection depends on the desired fluid control type.

Flush ports (Fig.2):

Allow for cleaning of solids trapped within the body cavities that can obstruct the flow or prevent the valve from closing. Depending on the process, purging can be made with air, steam, liquids, etc.

Other materials of construction:

Ductile iron, carbon steel, stainless steels (AISI 317, ...), special alloys (254SMO, Hastelloys, ...), etc.

Fabricated valves:

ORBINOX designs, produces and delivers special fabricated valves for special process conditions (big sizes and/or high pressures).

EXT design:

Modified version of the EX model with face to face according to MSS SP-81.
Standard flange connection from DIN PN 10, ANSI 150, to AS "D". Sizes available up to DN 600.

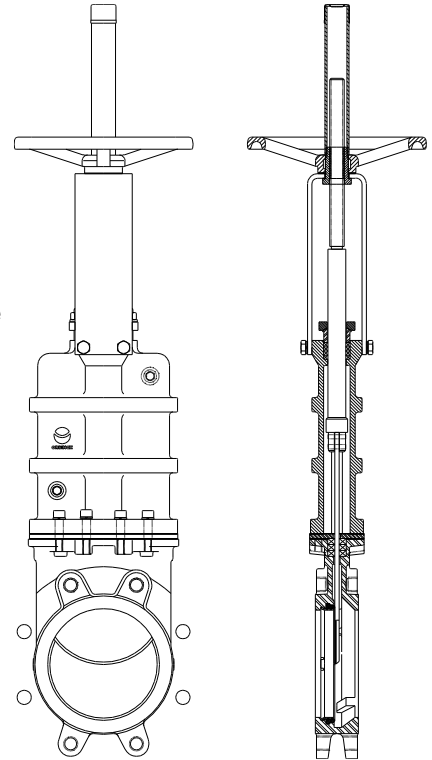

Fig.1

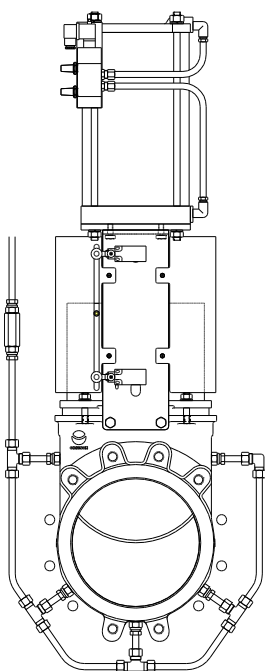

Fig.2

SURFACE TREATMENTS

Valve components can be protected or coated for a longer life expectancy, depending on the application of the valves and the valve service conditions. At ORBINOX we can offer alternative treatments and coatings for the different valve components to improve their properties against abrasion (Stellite, Polyurethane...), against corrosion (Halar, Rilsan, Galvanised...) and against adherence (Polishing, PTFE...).

We recommend to contact our technical department.

ACTUATOR TYPES

MANUAL:

- Handwheel (rising stem)
- Handwheel (non-rising stem)
- Chainwheel
- Lever
- Bevel Gear
- Other (square nut)

AUTOMATIC:

- Electric (rising & non-rising stem)
- Pneumatic (single & double-acting)
- Hydraulic

All actuators supplied by ORBINOX are interchangeable

ACCESSORIES:

- Mechanical Stops
- Actuator manual override
- Positioners
- Proximity Switches
- Stem Extensions

- Locking device
- Solenoid valves
- Limit Switches
- Floor stands

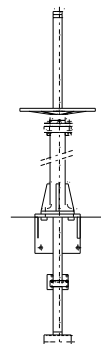

Wide range of valve extensions available

Please contact our Technical Department



Standard Handwheel (Rising Stem)



Handwheel (Non Rising Stem)



Pneumatic Cylinder



Electric



Lever

TEMPERATURE CHART

SEAT / SEALS

PACKING

Material	Max.T (°C)	Applications
Metal/Metal	>250	High temp./Low tightness
EPDM (E)	120	Acids and non mineral oils
NBR (N)	120	Resistance to petroleum products
FKM-FPM (V)	200	Chemical service/High temp.
VMQ (S)	250	Food service/High temp.
PTFE (T)	250	Corrosion resistance

Material	Max.T (°C)	pH
PTFE impregn. synth. fibre (ST)	250	2-13
Braided PTFE (TH)	260	0-14
Graphited (GR)	600	0-14
Ceramic fibre (FC)	1200	--

NOTE: all types include an elastomere O-ring (same material as seal), excluding TH, GR and FC.

More details and other materials under request

SEAT TYPES

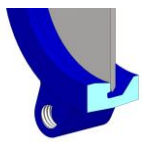

METAL/METAL

For applications with:

- High temperature
- High density media application
- In those cases when full tightness is not required

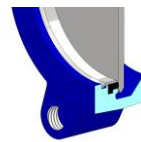

RESILIENT TYPE "A"

- Standard resilient seat.
- Temperature limitations according to the selected seat material. Review the above chart or contact our Technical Department for more information.
- Seat with replaceable retainer ring

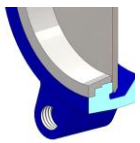

TYPE "B" SEAT (metal/metal)

For applications with:

- High temperature
- High density media application
- In those cases when full tightness is not required
- Replaceable design without disassembling the valve

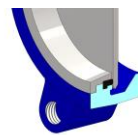

TYPE "B" SEAT (resilient)

- Temperature limitations according to the selected seat material. Review the above chart or contact our Technical Department for more information.
- Replaceable and reinforced seat ring available in different materials such as: stainless steel, CA1 5, Ni Hard,...

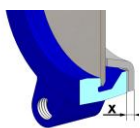

DEFLECTION CONE "C"

- Deflects the media away from any valve internal exposed parts (gate, seat, .)
- Material: AISI 316, CA15, Ni-Hard, etc.
- Face-to-face dimension increases:
DN 50 to DN 250 X = 9mm
DN 300 to DN 600 X = 12mm
Larger diameters on request

VALVE EXTENSIONS

The extension on a valve allows the operator to open or close the valve from a distance. Different types of extensions can be used depending on the application and the distance from the gate to the actuator.

1- Floor stand

- A pipe of the required length is added to the valve stem.
- Stem and yoke assembly remain in the original position.
- A floor stand is normally used at the top of the extension for actuator installation purposes.
- Required dimensions:
 H1: distance from centre line of the pipe to the base of the floor.
 d1: (wall bracket) distance from the wall to the face of the connecting flange.

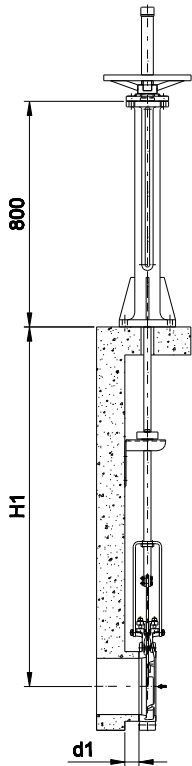

Fig. 1

Notes:

- a- Any type of actuator can be mounted on the floor stand such as Handwheel, Gear, Electric, etc.
- b- A wall bracket (Fig. A) is recommended at every 1.5m. This prevents any deviation or buckling of the extension rod.
- c- Standard construction of the floor stand is fabricated carbon steel. Other materials are available on request. (Fig. 1)
- d- A position indicator (optional) can be installed for easy visibility of the percentage of opening of the valve.
- e- Availability of supports for actuator floor stands (Fig. 2) upon request.

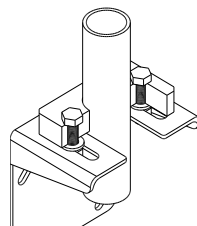

Fig. A

STANDARD PARTS LIST

Parts:	Material:
Spindle	Stainless Steel
Stem	Stainless Steel
Wall bracket	Carbon Steel- Epoxy coated
Slider	Nylon
Floor stand	Carbon Steel- Epoxy coated

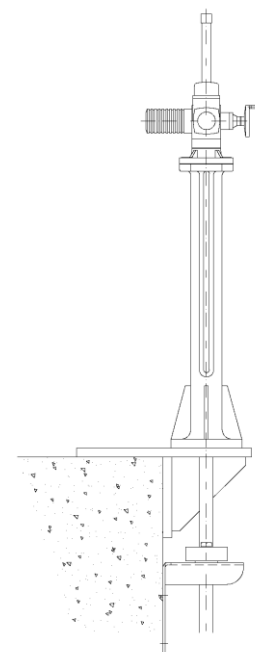
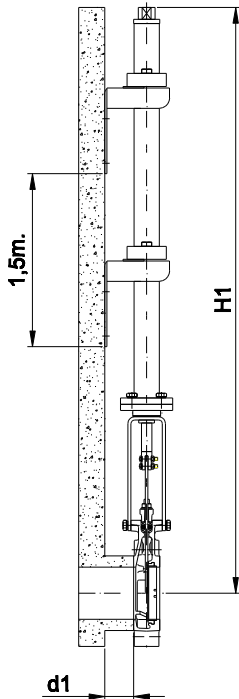

Fig. 2

2- Tube



- Stem and yoke assembly remains in its original position.
- Handwheel is replaced by a tube, which rotates at the time of operating the valve.
- Stem rises and lowers within the tube.
- Ideal for surface box operation, valve can be operated with a T-bar and a square nut.
- Required dimensions:
H1: distance from centre line of the pipe to the base of the floor.
d1: (wall bracket) distance from the wall to the face of the connecting flange.

Notes:

- a- Handwheel or square nut operated only.
- b- A wall bracket (Fig. A) is recommended at every 1.5m. This prevents any deviation or buckling of the extension rod.
- c- Standard construction of the extension is carbon steel epoxy coated. Other materials are available on request.

3- Universal joint

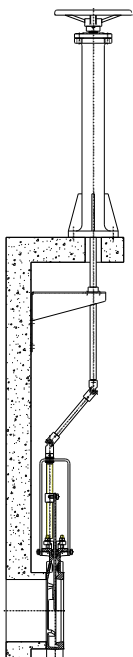

- Universal joints are used in those cases where the alignment of the extension between valve and actuator is not feasible.
- Please contact our technical department for more information.

4 - Extended support plates

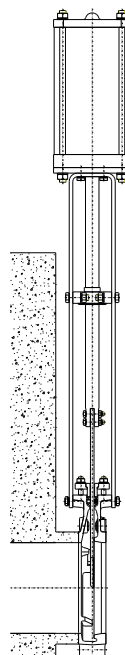

- Ideal where long extensions are not required.
- Guide bearing is installed at the mid point to prevent any deflection of the rod.

HANDWHEEL (rising stem)

- Standard manual actuator
- Consists of:
 - Handwheel: Epoxy coated Cast Iron
 - Stem
 - Stem nut
 - Stem protector
- Available from DN 50 to DN 1000
- Options:
 - Locking Device
 - Extensions

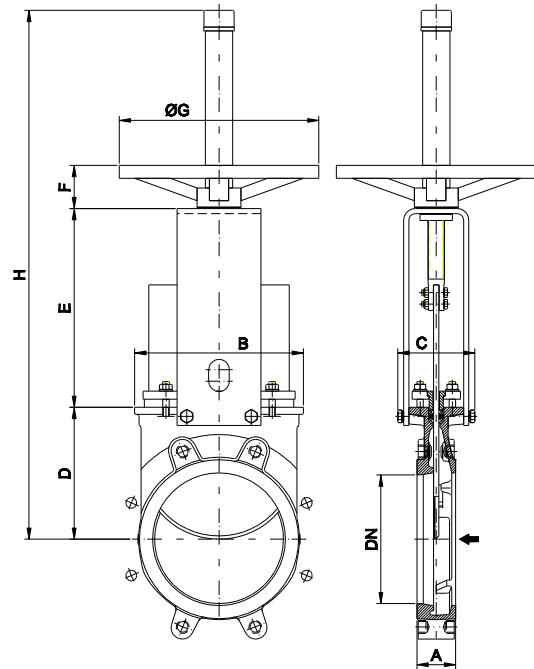

DN	A	B	C	D	E	F	ØG	H	Weight (kg.)
50	40	119	100	105	129	47	225	420	7
65	40	134	100	115	146	47	225	450	8
80	50	149	100	124	162	47	225	475	9
100	50	169	100	140	187	47	225	520	11
125	50	180	100	150	211	47	225	600	15
150	60	210	100	175	237	47	225	652	18
200	60	262	119	205	309	67	310	822	30
250	70	318	122	250	364	67	310	1022	44
300	70	372	122	300	414	67	310	1122	58
350	96	431	197	338	486	66	410	1323	96
400	100	486	197	392	536	66	410	1427	124
450	106	540	201	432	588	66	550	1594	168
500	110	602	201	485	648	66	550	1707	192
600	110	708	201	590	748	66	550	2022	245
700	110	834	380	686	890	74	800	2778	405
750	110	884	380	760	945	74	800	2900	455
800	110	1015	320	791	989	74	800	2980	512
900	110	1040	320	895	1118	74	800	3215	680
1000	110	1146	320	975	1220	74	800	3400	865

HANDWHEEL (non-rising stem)

- Recommended for installation where space is limited.

- Consists of:

- Handwheel
 - DN 50-300: Aluminium
 - DN ≥ 350: GJS400 (GGG40)
- Stem
- Yoke bushing
- Stem nut fixed to the gate

- Available from DN 50 to DN 1000

- Options:

- Locking Device
- Extension
- Square Nut Drive

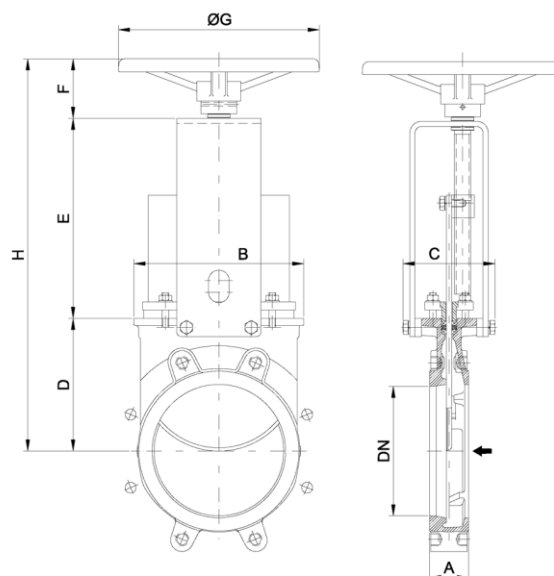

DN	A	B	C	D	E	F	ØG	H
50	40	119	125	105	144	63	225	312
65	40	134	125	115	161	63	225	339
80	50	149	125	124	177	63	225	364
100	50	169	125	140	202	63	225	405
125	50	180	125	150	226	63	225	439
150	60	210	125	175	252	63	225	490
200	60	262	142	205	317	73	310	595
250	70	318	142	250	372	73	310	695
300	70	372	142	300	422	73	310	795
350	96	431	197	338	509	98	410	945
400	100	486	197	392	559	98	410	1049
450	106	540	201	432	611	98	550	1141
500	110	602	201	485	671	98	550	1254
600	110	708	201	590	771	98	550	1459
700	110	834	380	686	900	151	800	1737
750	110	884	380	760	945	151	800	1856
800	110	1015	320	791	997	151	800	1939
900	110	1040	320	895	1128	151	800	2174
1000	110	1150	320	975	1255	151	800	2381

CHAINWHEEL

- Recommended for elevated installations.
- Consists of:
 - Chainwheel: Epoxy coated Cast Iron
 - Stem
 - Stem nut
 - Stem protector
- Available from DN 50 to DN 600
- Options:
 - Locking Device
 - Extension
 - Rising Stem and Non-rising Stem

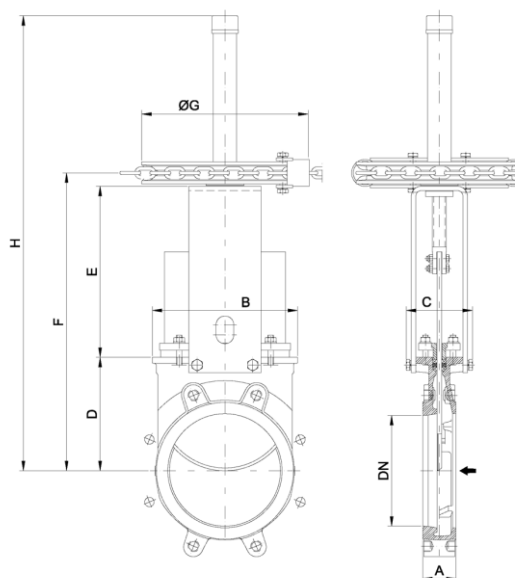

DN	A	B	C	D	E	F	ØG	H
50	40	119	100	105	129	253	225	420
65	40	134	100	115	146	280	225	450
80	50	149	100	124	162	305	225	475
100	50	169	100	140	187	347	225	520
125	50	180	100	150	211	380	225	600
150	60	210	100	175	237	431	225	652
200	60	262	119	205	309	538	300	822
250	70	318	122	250	364	638	300	1022
300	70	372	122	300	414	738	300	1122
350	96	431	197	338	486	856	454	1323
400	100	486	197	392	536	960	454	1427
450	106	540	201	432	588	1052	454	1594
500	110	602	201	485	648	1165	454	1707
600	110	708	201	590	748	1370	454	2022

LEVER

- Recommended for quick opening and closing.
- Consists of:
 - Lever
 - Stem
 - Yoke sleeve
 - Lever lock
- Available from DN 50 to DN 300

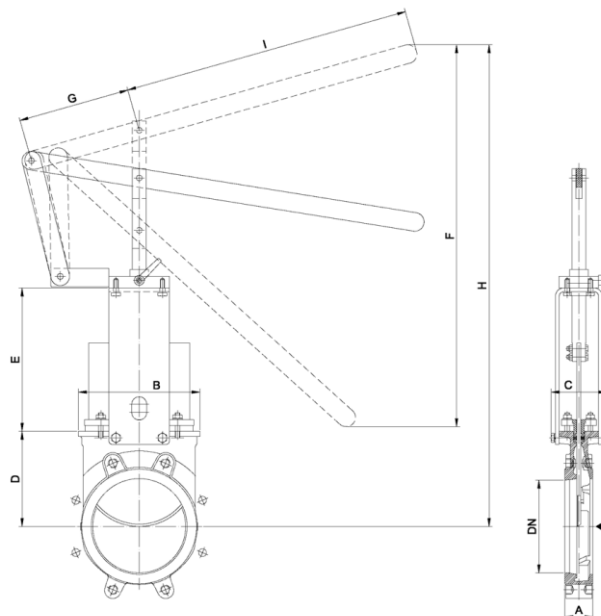

DN	A	B	C	D	E	F	G	H	I
50	40	119	100	105	129	256	150	408	315
65	40	134	100	115	146	259	150	435	315
80	50	149	100	124	162	307	150	509	315
100	50	169	100	140	187	439	150	637	415
125	50	180	100	150	211	529	150	755	415
150	60	210	100	175	237	620	150	895	415
200	60	262	119	205	309	822	235	1038	620
250	70	318	122	250	364	995	235	1307	620
300	70	372	122	300	414	1166	235	1578	620

GEAR

- Recommended for valves larger than DN 350 and working pressures greater than 3.5 bar
- Consists of:
 - Stem
 - Stem protector
 - Bevel Gear Actuator with Handwheel
- Available from DN 200 to DN1200
- Options:
 - Locking device
 - Extension
 - Chainwheel
 - Rising stem and non-rising stem
- Standard reduction ratio of 4:1

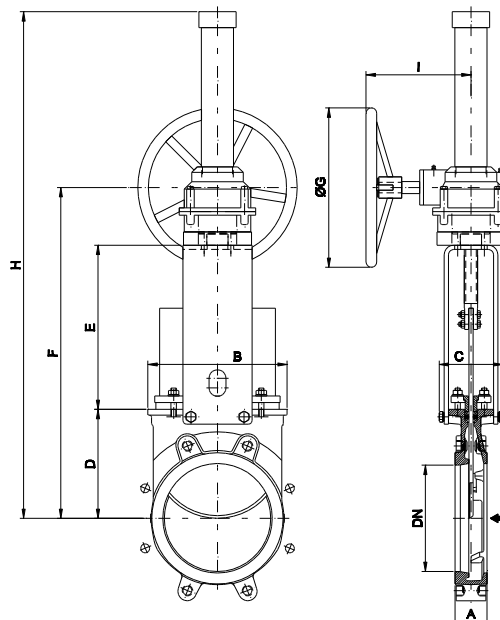

DN	A	B	C	D	E	F	ØG	H	I
200	60	262	119	205	309	584	300	994	200
250	70	318	122	250	364	684	300	1094	200
300	70	372	122	300	414	784	300	1194	200
350	96	431	197	338	472	857	450	1657	262
400	100	486	197	392	522	961	450	1761	262
450	106	540	201	432	574	1053	450	1853	262
500	110	602	201	485	634	1166	450	1966	262
600	110	708	201	590	734	1371	450	2171	262
700	110	834	380	686	890	1623	450	2423	262
750	110	884	380	760	945	1755	450	2555	262
800	110	1015	320	791	993	1886	650	2926	260
900	110	1040	320	895	1123	2120	650	3160	288
1000	110	1146	320	975	1220	2302	650	3342	288
1200	150	1390	450	1037	1522	2695	850	3935	365

PNEUMATIC CYLINDER

- The standard pneumatic actuator (double acting on-off cylinder) consists of:
 - $\varnothing \leq 300$: Aluminum barrels
 - $\varnothing \geq 350$: Composite barrels
 - Aluminum end covers
 - Stainless steel (AISI 304) piston rod
 - Nitrile coated steel piston
- Available from DN 50 to DN 1000
- Supply Pressure: min. 3.5 bar - max. 10 bar. Actuator designed with 6 bar air supply.
- For valves installed in a horizontal position, we recommend U-type support plates and/or actuator support.
- Options:
 - Hard anodized barrel and covers
 - Stainless steel barrel and covers
 - Over/Undersized cylinder
 - Manual override
 - Fail safe system (Page EX-14)
 - Limit switches
- Instrumentation (on request):
 - Positioners
 - Solenoid valves
 - Flow regulators
 - Air preparation units

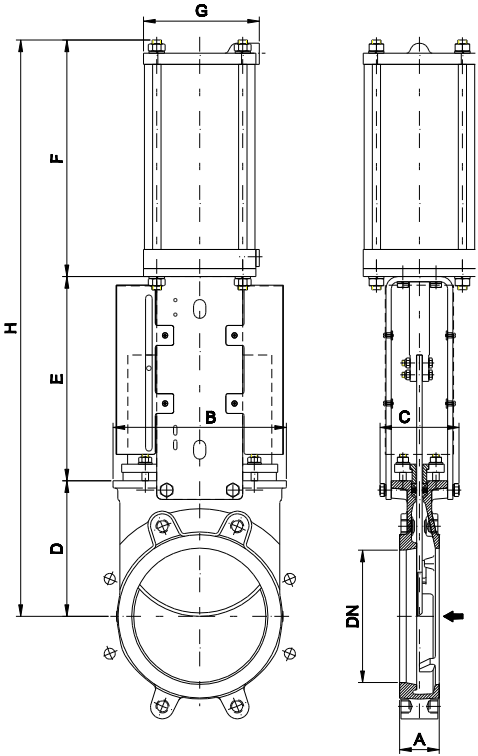

DN	A	B	C	D	E	F	G	H	Weight (kg.)	Standard Cyl.	Connect.
50	40	119	100	105	129	178	115	412	9	C100/62	1/4" G
65	40	134	100	115	146	193	115	454	10	C100/77	1/4" G
80	50	149	100	124	162	211	115	497	11	C100/95	1/4" G
100	50	169	100	140	187	231	115	558	14	C100/115	1/4" G
125	50	180	100	150	211	271	140	632	20	C125/143	1/4" G
150	60	210	100	175	237	296	140	708	25	C125/168	1/4" G
200	60	262	119	205	309	358	175	872	44	C160/220	1/4" G
250	70	318	122	250	364	428	220	1042	67	C200/270	3/8" G
300	70	372	122	300	414	478	220	1192	82	C200/320	3/8" G
350	96	431	197	338	500	549	277	1387	135	C250/375	3/8" G
400	100	486	197	392	550	599	277	1541	165	C250/425	3/8" G
450	106	540	270	432	598	680	382	1710	220	C300/475	1/2" G
500	110	602	270	485	658	730	382	1873	280	C300/525	1/2" G
600	110	708	270	590	758	830	382	2178	330	C300/625	1/2" G
700	110	834	380	686	875	985	444	2546	520	C350/730	3/4" G
750	110	884	380	760	930	1035	444	2725	585	C350/780	3/4" G
800	110	1015	320	791	974	1085	444	2850	650	C350/830	3/4" G
900	110	1040	320	895	1105	1202	515	3202	850	C400/930	3/4" G
1000	110	1146	320	975	1217	1296	515	3488	1060	C400/1030	3/4" G

FAIL SAFE SYSTEM

SINGLE ACTING (SPRING RETURN)

- This actuator (single acting cylinder) consists of:
 - Aluminum barrel and covers
 - Steel spring
 - Stainless Steel (AISI 304) piston rod
 - Nitrile coated steel piston
- Available from DN 50 to DN 300
- Supply pressure: min. 5 bar - max. 10 bar
- Options:
 - Fail open
 - Fail close

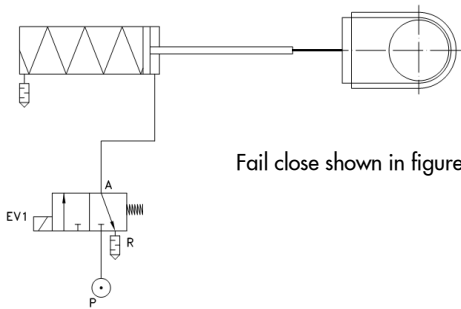

Fail close shown in figure

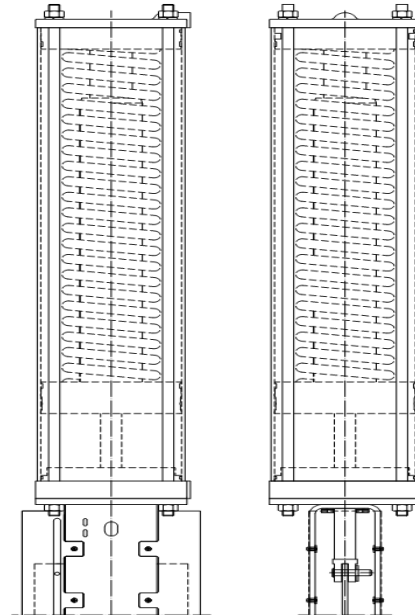

DOUBLE ACTING WITH AIR TANK

- Fail safe systems consists of: double acting pneumatic cylinder, air tank and all the necessary elements according to the available options (solenoid valve, spool valve,...)
- Different solution available (pressure switches,...)
- Available for all diameters
- Supply Pressure: min. 3.5 bar - max.10 bar

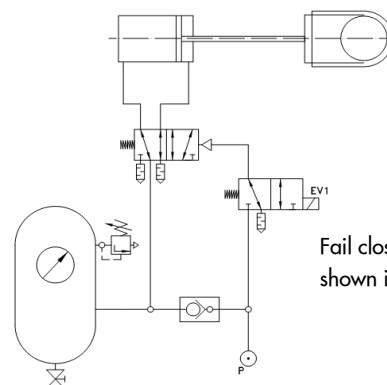
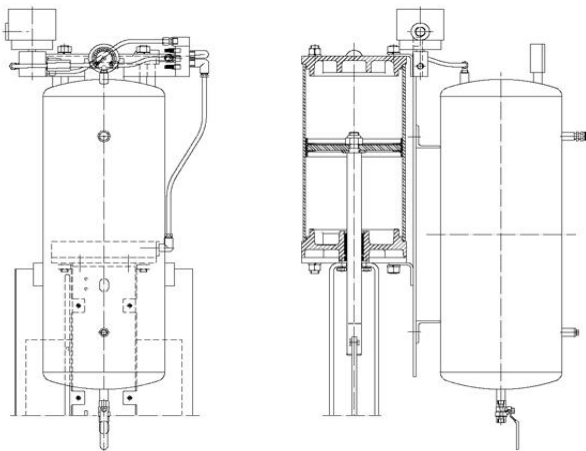

Fail close in power failure shown in figure

ELECTRIC ACTUATOR

- Consists of:
 - Electric actuator
 - Rising stem
 - Motor support yoke flange acc. to ISO 5210 / DIN 3338
- The standard electric motor is equipped with:
 - Manual emergency operation
 - Limit switches (open/closed)
 - Torque switches
- Available from DN 50 to DN 1200
- Wide range of types and marks available to meet customer's needs.
- Option:
 - Non rising stem

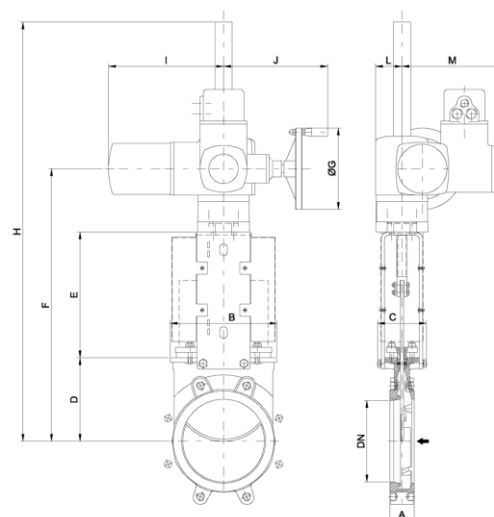

DN	A	B	C	D	E	F	ØG	H	I	J	L	M	Stem Ø x pitch	Torque (Nm)
50	40	119	100	105	129	377	160	547	265	249	62	238	20 x 4	10
65	40	134	100	115	146	404	160	574	265	249	62	238	20 x 4	10
80	50	149	100	124	162	429	160	599	265	249	62	238	20 x 4	10
100	50	169	100	140	187	470	160	640	265	249	62	238	20 x 4	10
125	50	180	100	150	211	504	160	674	265	249	62	238	20 x 4	15
150	60	210	100	175	237	555	160	1055	265	249	62	238	20 x 4	20
200	60	262	122	205	309	669	160	1169	265	249	62	238	25 x 5	30
250	70	318	122	250	364	769	160	1269	265	249	62	238	25 x 5	45
300	70	372	122	300	414	869	160	1369	265	249	62	238	25 x 5	40
350	96	431	197	338	472	940	200	1440	283	254	65	248	35 x 6	70
400	100	486	197	392	552	1044	200	1544	283	254	65	248	35 x 6	90
450	106	540	270	432	610	1172	200	1672	283	254	65	248	35 x 6	110
500	110	602	270	485	670	1280	200	1780	283	254	65	248	35 x 6	95
600	110	708	270	590	800	1565	315	2065	389	336	91	286	35 x 6	140
700	110	834	380	686	900	1763	315	2846	389	336	91	285	40 x 7	120
750	110	884	380	760	945	1882	315	2965	389	336	91	286	40 x 7	140
800	110	1015	320	791	980	1948	315	3031	389	336	91	286	50 x 8	180
900	110	1040	320	895	1087	2157	400	3240	389	339	91	286	50 x 8	220
1000	110	1146	320	975	1200	2350	400	3431	389	339	91	286	50 x 8	300
1200	150	1390	450	1037	1485	2732	500	4137	430	365	117	303	60 x 9	480

FLANGE AND BOLTING DETAILS

EN 1092-2 PN10

DN	K	n°	M	T	⊙ ⊕ ⊗
50	125	4	M-16	11	4 - 0 - 0
65	145	4	M-16	11	4 - 0 - 0
80	160	8	M-16	11	4 - 0 - 4
100	180	8	M-16	11	4 - 0 - 4
125	210	8	M-16	11	4 - 0 - 4
150	240	8	M-20	14	4 - 0 - 4
200	295	8	M-20	14	4 - 0 - 4
250	350	12	M-20	18	6 - 0 - 6
300	400	12	M-20	18	6 - 0 - 6
350	460	16	M-20	22	6 - 4 - 6
400	515	16	M-24	24	6 - 4 - 6
450	565	20	M-24	24	8 - 6 - 6
500	620	20	M-24	24	8 - 6 - 6
600	725	20	M-27	24	8 - 6 - 6
700	840	24	M-27	20	10 - 6 - 8
800	950	24	M-30	20	10 - 6 - 8
900	1050	28	M-30	20	12 - 8 - 8
1000	1160	28	M-33	20	12 - 8 - 8
1200	1380	32	M-36	30	22 - 6 - 4

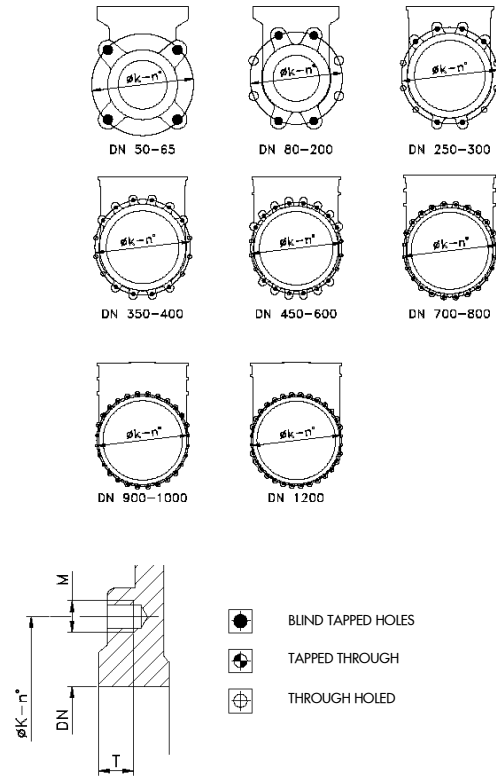

ANSI B16.5 , class 150 (*)

DN	K	n°	M	T	⊙ ⊕ ⊗
2"	4 3/4"	4	5/8" - 11 UNC	3/8"	4 - 0 - 0
2 1/2"	5 1/2"	4	5/8" - 11 UNC	3/8"	4 - 0 - 0
3"	6"	4	5/8" - 11 UNC	3/8"	4 - 0 - 0
4"	7 1/2"	8	5/8" - 11 UNC	3/8"	4 - 0 - 4
5"	8 1/2"	8	3/4" - 10 UNC	3/8"	4 - 0 - 4
6"	9 1/2"	8	3/4" - 10 UNC	1/2"	4 - 0 - 4
8"	11 3/4"	8	3/4" - 10 UNC	1/2"	4 - 0 - 4
10"	14 1/4"	12	7/8" - 9 UNC	3/4"	6 - 0 - 6
12"	17"	12	7/8" - 9 UNC	3/4"	6 - 0 - 6
14"	18 3/4"	12	1" - 8 UNC	7/8"	4 - 4 - 4
16"	21 1/4"	16	1" - 8 UNC	1"	6 - 4 - 6
18"	22 3/4"	16	1 1/8" - 7 UNC	1"	6 - 4 - 6
20"	25"	20	1 1/8" - 7 UNC	1"	8 - 6 - 6
24"	29 1/2"	20	1 1/4" - 7 UNC	1"	8 - 6 - 6
28"	34"	28	1 1/4" - 7 UNC	3/4"	12 - 6 - 10
30"	36"	28	1 1/4" - 7 UNC	3/4"	12 - 8 - 8
32"	38 1/2"	28	1 1/2" - 6 UNC	3/4"	12 - 8 - 8
36"	42 3/4"	32	1 1/2" - 6 UNC	3/4"	14 - 8 - 10
40"	47 1/4"	36	1 1/2" - 6 UNC	3/4"	14 - 12 - 10
42"	49 1/2"	36	1 1/2" - 6 UNC	3/4"	14 - 12 - 10
48"	56"	44	1 1/2" - 6 UNC	13/16"	26 - 10 - 8

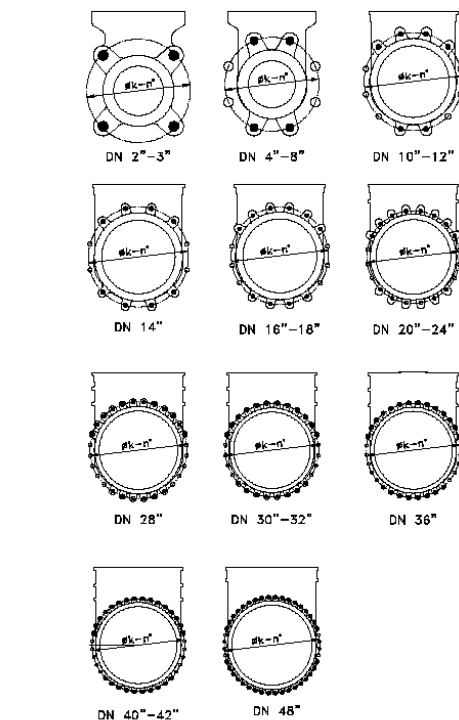

(*) From DN 24", acc. To MSS SP 44 (class 150)